

ABOUT US

AMOB S.A. provides one of the biggest ranges of specialised equipment for the tube and pipe bending industry worldwide.

Founded in 1960 by António Martins Oliveira Barros (AMOB) and followed by his two sons Luis and Manuel, we have progressively become the world's leading manufacturer of metalworking technologies.

We serve the global market with exceptional machinery and tooling for tube and pipe bending, section bending and roll forming lines – ranging from simple, manual appliances to complex, fully-electric CNC powered systems.

AMOB designs, develops, retails and services a variety of products for a range of leading industrial industries including automobile and shipping, aeronautics and construction amongst others.

MANUFACTURING

AMOB has a proud history of manufacturing in Portugal, employing over 140 staff members at our main plant in Porto. Our recently-renewed headquarters covers 18000m², and is equipped with the highest technological production equipment including CNC machining centres, lathes and milling machines, as well as sheet metal cutting and bending machinery for guaranteed high fabrication standards. Elsewhere, AMOB has commercial facilities in Russia, Brazil, Spain, Benelux, France and a worldwide network of over 70 agencies and technical centers – providing customer support wherever you are!



TECHNICAL

Our products are designed in our technical department by a team of highly-skilled engineers - we offer competitive solutions without compromising on quality.

Over the years, AMOB has grown with our customers' requirements and the market demand. We're just as passionate about growing and developing our products as we are about our client relationships.



Thank you for choosing AMOB!



Head quarters

AMOB Portugal
Rua Padre Domingos J. Pereira 1249
4760 – 563 Louro - V.N. Famalicão
Portugal
Telf. 00 351 252 330 900
sales@amob.pt
www.amobgroup.com

Delegations

AMOB España
Polg. Ind. Málpica-Alfindém, Calle Olmo, nº32
50171 La Puebla de Alfindém
Zaragoza - España
Tel. 0034 976 105 964

AMOB Brasil
Rod. Geraldo Scavone, 2300 – Galpão 34
12305-490 Jacarei – SP
São Paulo - Brasil
Tel. 0055 (12) 3958 4657

AMOB Russia
107023, Moscow,
Shelkovskoe shosse, 100
Russian Federation
Tel. 007 (495) 374 95 86

AMOB Benelux
Kantoor: Kloosterakker 71
6602 HT Wijchen
Nederland
Tel. 0031 8870 80700

AMOB France
7, avenue de l'Europe
C.I.T. 59223 RONCQ
France
Tel. 0033 (0) 328 350 834

ROLLFORMING.ENG.V0602017

roll forming lines



AMOB

PF

Roll forming lines

Our custom designed and manufactured roll forming lines put AMOB at the forefront of the market. Since 1960, our innovative solutions have given us a huge wealth of experience and technical insight in this area.

We can meet any requirement through customisation and innovation - from decoiling, through to roll forming and then onto bending if required.

We're very proud of our reputation for providing a complete turn key package. If a reliable, effective and highly productionised roll forming line is what you require – then look no further than AMOB.

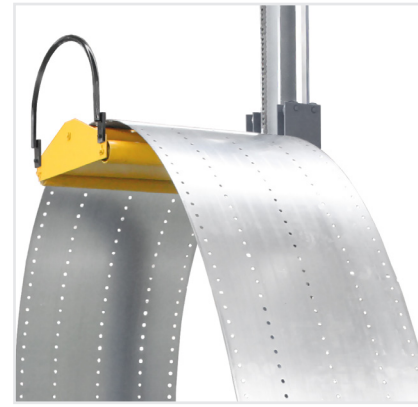

Vertical plate stock

This system eliminates the need for a traditional roll forming pit - allowing the plate to accumulate, ready for the forming process.

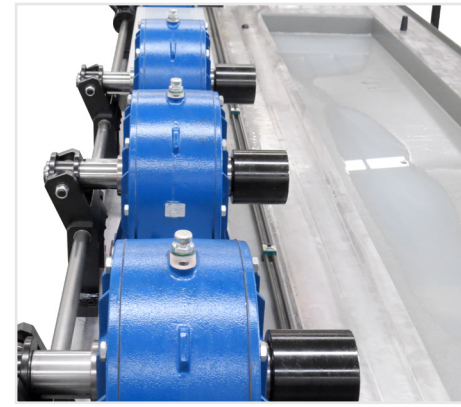

Versatility, diversity and production optimisation

Depending on the customer's needs, AMOB's roll forming lines can be equipped with several different, interchangeable systems to easily meet specific requirements. Quick cassette changes along with adjustable tooling - to produce a variety of bespoke profiles with different dimensions - make AMOB's roll forming lines both efficient and versatile.

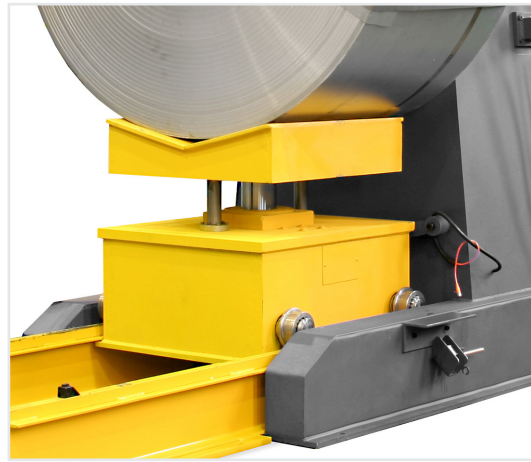
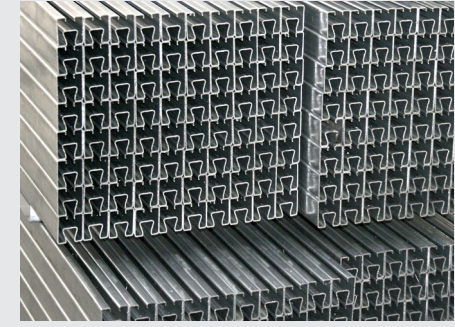
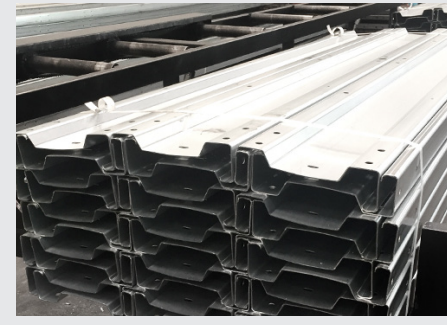
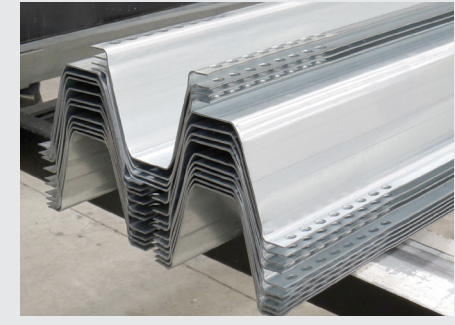
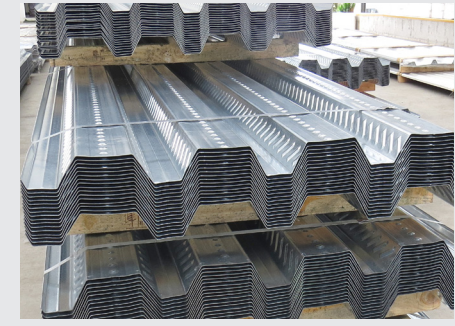
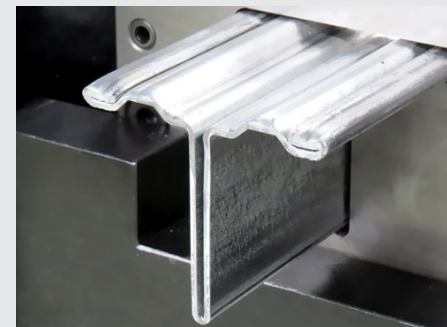
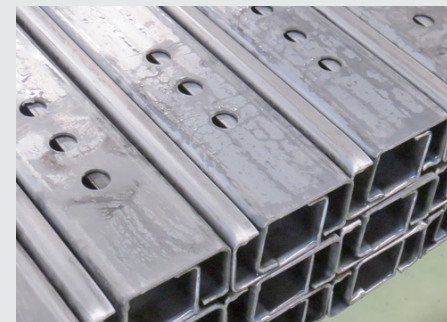
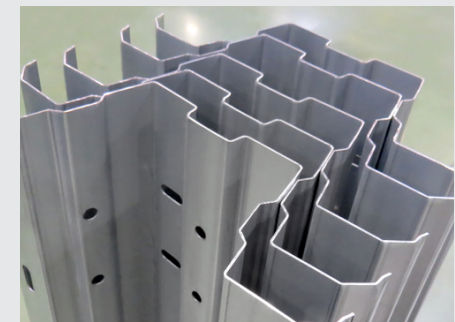
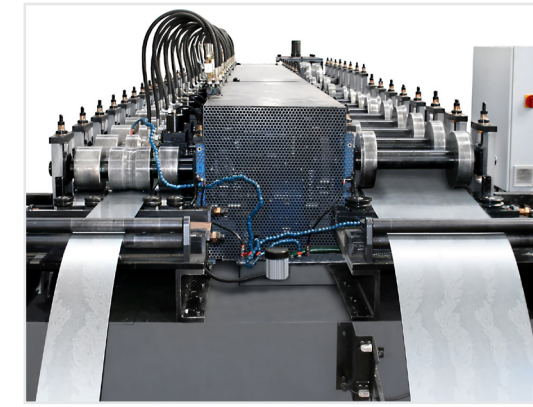

Decoilers

The AMOB decoiler range is one of the largest and most powerful in the world. Our offering ranges from light, mechanically-operated options all the way up to a completely motorised decoiler with a quick change integrated system - which has a capacity of up to 15 tonnes.

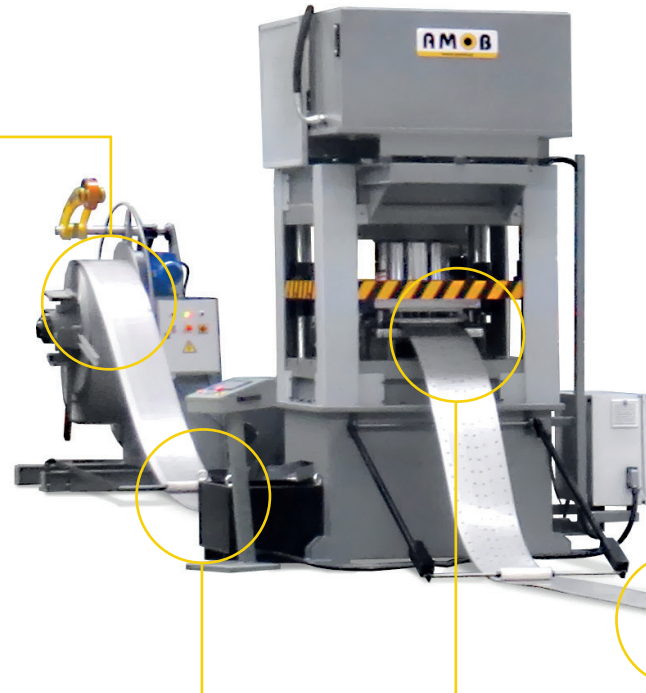
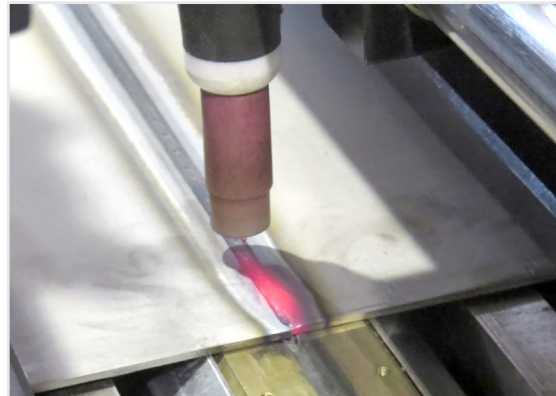

Plate end welding

This system enables plate ends to be welded quickly and automatically, significantly reducing waste and downtime.



Intermediate punching and forming stations

Our roll forming lines can incorporate several intermediate stations for punching, forming or marking. The different options available are endless, starting with a single punching or forming unit right the way through to a multi-tool CNC press.

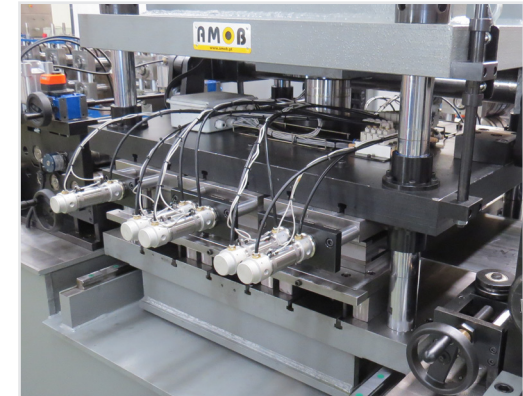

CNC control

AMOB's user-friendly CNC touch screen display enables full control of the automatic line in a synchronised and autonomous way.



PF15

CNC roll forming line
Decoiler, press, roll forming, cutting and offload system

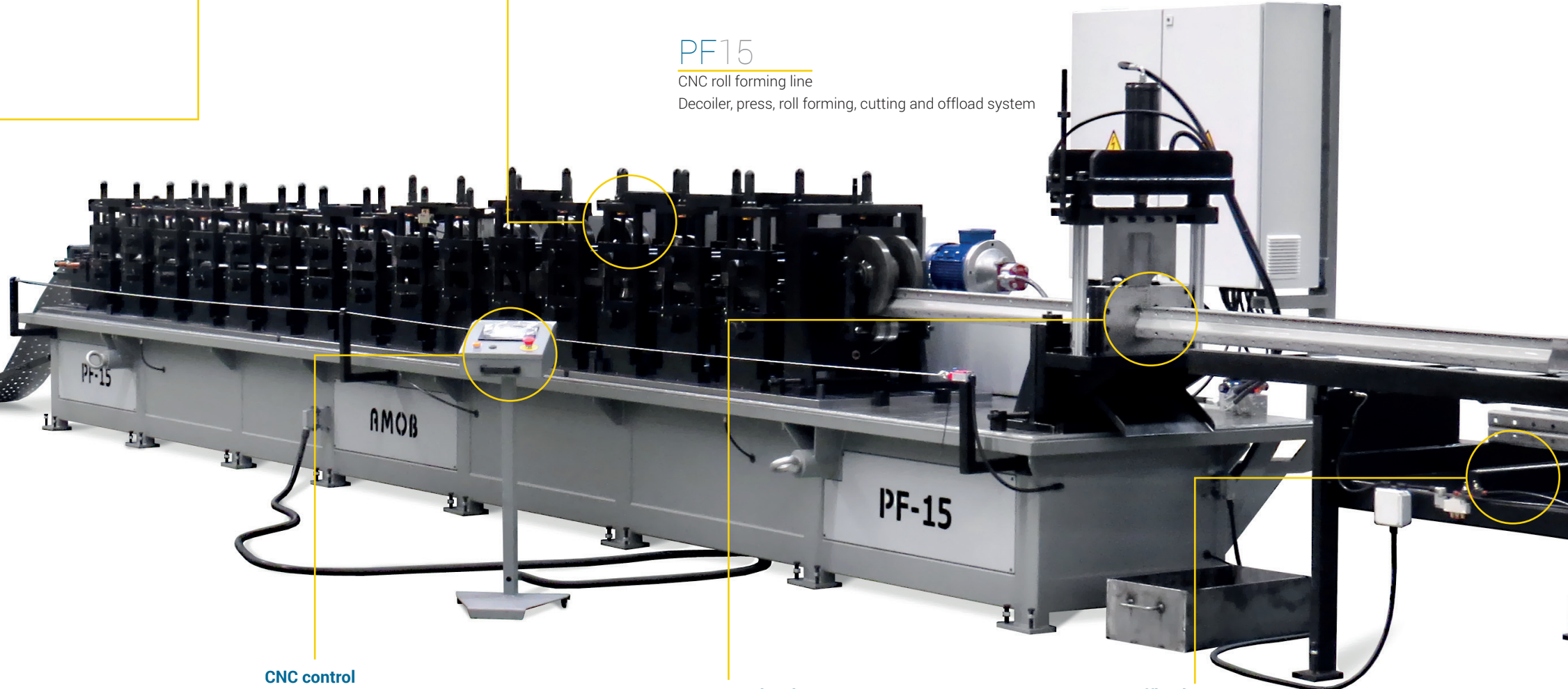

Cut-to-length

There is also an option to equip our roll forming lines with stationary or high speed cut-to-length systems.

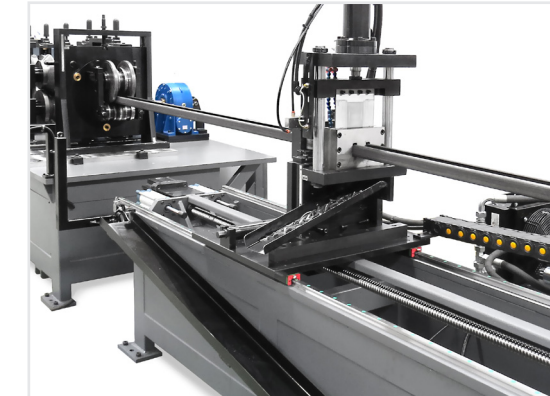

Offload systems

To increase the efficacy of the roll forming line, an automatic offload system can be incorporated to stack products on pallets or fill stillages.

